

PROSPECTUS

(Session 2024-25)



NALBARI COLLEGE, NALBARI

Estd. 1945

(Accredited by NAAC with "B" Grade in 2019)

.....with 79 years of glorious history of imparting quality education



Website: www.nalbaricollege.ac.in

E-mail id: nalbaricollege1945@gmail.com

Nalbari College, Nalbari

MESSAGE FROM THE PRINCIPAL.....



Dear Students,

Welcome to Nalbari College, a premier institution for higher education in the state. Established through the untiring efforts of Late Trailokya Nath Goswami, Late Prabhat Ch. Goswami, Late Haricharan Pathak, Late Harekrishna Goswami and many others, this College has been engaged in disseminating knowledge and imparting skills to the students since 1945. Over the last seven decades we are growing with addition of streams, subjects, courses and tried our best to meet the needs of our society and the region in the field of education. At the same time we are also in practice of a holistic effort to make education a vibrant sphere of learning by giving our students an opportunity to hone and showcase their talents in the field of literature, culture and sports. There are different centers and cells to look after the students' requirements beyond their syllabus oriented academic pursuits, like career planning, performing arts, music, visual arts, debating skill, environmental awareness and regeneration etc. We are also planning to introduce different life skill training programmes under the banner of 'Earn while Learn' to explore the prospects and avenues of entrepreneurship for our student in today's world. Now the College has 18 departments in arts, science and professional that imparting education from Higher Secondary to Post Graduate levels. The NEP-2020 has implemented last year. The implementation of a policy like NEP-2020 with massive structural change is a challenging tusk to achieve. With our 79 years of experience, we are giving our all sorts of effort to make all those changes students friendly and we hope that our opportunate students will get a hassle free atmosphere under the guidance of our experienced faculty members. Finally, I express my gratitude to all those whose contributions have brought the College to this point, and expect to build upon it with the contributions and cooperation of all the stakeholders. With these words I welcome you once again on behalf of the College community, in the hope that your years as a student will enrich you and this institution.



(Dr. Kamal Nayan Patowary)
Principal
Nalbari College, Nalbari

Published by:
Principal
Nalbari College, Nalbari
nalbaricollege1945@gmail.com

Modelled, Edited and Composed by:
Internal Quality Assurance Cell,(IQAC)
Nalbari College, Nalbari
iqacnc@gmail.com

Nalbari College..... with seven decades of illustrious academic heritage



The College Crest

The rising sun at the centre symbolizes awakening and enlightenment. The ever expanding circles stand for the ever widening bounds of knowledge that remain to be explored. The full bloomed lotus suggests a being blessed with the sacred rays of wisdom and the two buds on both sides stand for the masses eagerly waiting to be enlightened. The petals arranged in the inner circles symbolize the ever increasing numbers of enlightened souls on the move towards the horizon to dispel the darkness of ignorance and explore new frontiers.

Vidyayaa Vindate Amritam.....

As a college which is approaching 79 years of its glorious existence, Nalbari College is guided by the motto adorning its emblem "*Vidyayaa Vindate Amritam*" i.e. Scholarship offers eternity.

Vision of the College

To provide outstanding education and training to our learners to achieve their goals.
To reach out to the unreached.
To forge institutional, departmental and individual linkage with society.
To turn the college into a nodal facilitating centre for inclusive and sustainable development of the region.

Mission of the College

To impart quality education to the learners.
To create better academic environment in order to produce competent and industrious

human resource.

To provide student- centered academic and personal enrichment opportunities to enhance lifelong learning.

To make education more relevant in the global perspective.

To expand and accommodate with the changing traits of higher education.

Through The Lens of Time....

Nalbari College is one of the premier colleges of Assam. Established way back in pre-independent era (**on 4th July, 1945**), this college has taken a pioneering role in shaping and promoting higher education in the entire lower Brahmaputra valley. In the beginning, the college was affiliated to the Calcutta University, but in 1948, when Gauhati University was established, it came under the academic jurisdiction of the latter. The college received the UGC recognition under Section 2(f) in 1962. Beginning with a modest number of only 28 students, today it has a sizable strength of about 4450 students (including Higher Secondary programme). Spreading over 16 acres of land, the college has a built up area of approximately 8 acres.

Nalbari College is a multi-streamed co-educational institution imparting education right from Higher Secondary to PG level. At present it offers UG programmes for 09 Humanities & Social Science departments and 07 Science departments and PG programme for Assamese and English. Further, since 2013, the College with approval from the University has introduced two more professional courses i.e. Bachelor of Physical Education (B.P.E) and Bachelor of Science in Information Technology (B.Sc. IT) on regular basis. Nalbari College is the first college to start B.P.E in entire Assam. Besides, the college has two other self financing courses i.e. Bachelor of Computer Application (BCA) and Post Graduate Diploma in Computer Application (PGDCA). Further the College is offering 19 Add-On Courses for its students.

In order to facilitate those students who cannot pursue regular education the college offers distance learning facilities through its affiliating centres of Center for Distance & Online Education under Gauhati University, Krishna Kanta Handique State Open University and Assam State Open School.

The College has introduced Four-Year under graduate programme (FYUGP) already. The detail of the programme has been mentioned in subsequence pages of the Prospectus.

Our Strengths:

Our glorious past is the main inventory of strength of the College.

The tradition of ever improving teaching learning process has successfully been translated into positive outcome. This is clearly reflected in the brilliant results of the College for last several years. Every year our students clinched the rank in the University.

Our well known alumni contributing towards society in diverging directions with their activities. They are the pride and the strength of the college.

Assessment and Accreditation by NAAC

In April 29th and 30th, 2019, the Peer Team of National Assessment and Accreditation

Council (NAAC), Bangalore, consisting of three renowned educationists of the country visited the College. On the basis of the assessment made by the peer team the college will be accredited with grade “B”.

Four-Year under Graduate Degree Programme (FYUGP)

(* For details see the Gauhati University website (<https://gauhati.ac.in>))

The Four-Year Undergraduate Programme (FYUGP) is based on the National Education Policy (NEP) 2020. The policy recognizes that higher education plays an extremely important role in promoting human as well as social well-being. The policy also endeavours developing India as envisioned in its Constitution – a democratic, just, socially conscious, cultured, and humane nation upholding liberty, equality, fraternity, and justice for all. NEP 2020 notes that “given the 21st-century requirements, quality higher education must aim to develop good, thoughtful, well-rounded, and creative individuals”.

The FYUGP is designed to cater to the diverse academic needs of the student and seeks to offer options of multiple entries / exits and obtain a Certificate or a Diploma or Degree with or without Major or a Degree (Honours) with Research at various levels as stipulated under the policy.

Objectives

The aims and objectives of the FYUGP under NEP 2020 are to highlight certain fundamental principles that would guide both the education system at large, as well as individual educational institutions. These objectives have a direct bearing on the curricula for different levels of higher education:

Programme and curricular components

Overview and structure

The complete FYUGP consists of 8 semesters, to be completed in a minimum of 4 academic years. Each academic year has two semesters. Each semester has a maximum credit allocation of 22. The credit requirements for GU's FYUGP is as follows

- (a) Semester I : 22
- (b) Semester II : 22
- (c) Semester III : 22
- (d) Semester IV : 22
- (e) Semester V : 22
- (f) Semester VI : 22
- (g) Semester VII : 22
- (h) Semester VIII : 22
- (i) Total : 176

Course-wise credit requirements

Below, we provide the minimum credit requirement for various course along with a mention of their semesters (as prescribed by the UGC).

(a) Core Course

- a) First Major : 60 (Semesters 1-6)
- b) Minor : 12 (Semesters 1-6)
- c) Second Major (Double Major) : 48 (Semesters 1-6)

(b) Common Course

- a) Multidisciplinary : 9 (Semesters 1-3)
- b) Skill Enhancement Course (SEC) : 9 (Semesters 1-3)
- c) Valued Added Course (VAC) : 6 (Semesters 1, 2, 4)
- d) Ability Enhancement Course (AEC) : 8 (Semesters 1-2, 5-6)
- e) Internship : 4 (in any Semester from 3-6)
- f) Research Methodology : 4 (in any Semester in 5 or 7)

(c) For Honours and Honours with Research

- a) Advanced Core, Dissertation : 40 (Semesters 7, 8)

• Open Core Credits

From fourth to sixth semester, one will have time for 4 optional open core credits per semester, which one can utilise to study either of the Major or two Minors. They can also come handy, if one had changed a Minor subject in between.

• Double Major

If a student is ready to do some more hard work, he/she can take some extra online courses (from designated sources only) related to the Minors and can then convert one of the Minors to a second Major by the time one completes 3 / 4 years of study. This is over and above the first Major. In this case, one will have a Bachelor's Degree with Double Major.

FYUGP degrees & course structures

The FYUGP at GU is designed to offer two types of Bachelor's Degrees to the students at the end of the successful completion of the programme —

- (i) Bachelor's Degree in a Stream and
- (ii) Bachelor's Degree in a Discipline.

Curricular components

The entire FYUGP curriculum is divided into two parts – (a) Core Courses and (b) Common Courses, which are described below.

Core courses

The core course determine the ultimate degree, diploma or certificate a student will earn at the end of third (or 4th) year, 2nd Year or 1st Year respectively. A student needs to study at least 3 core subjects. In case of a bachelors degree in a stream the components of the core courses are major and minor or minors while bachelors degree in a discipline there are no major and minor. Usually, a student will choose one Major subject and two Minor subjects in case of degree in a stream. All core courses have a credit allocation of 4. All together, irrespective of any Major or Minor options, a student will necessarily need to study 21 courses with total credit allocation of 84 over a 3-year programme.

Major Course The minimum credit requirements for a Major Course over a 3-year period are 60 which translate to 15 courses (papers).

Minor Course The minimum credit requirements for a Minor Course over a 3-year period are 12 which translate to 3 courses (papers).

Common courses

As the name suggests, these courses will have to be studied by all students of FYUGP. Together the common courses have a credit allocation of 36 divided over five subdivisions. They are

- (a) Multidisciplinary Courses : Total Credits 9
- (b) Ability Enhancement Courses (AEC) : Total Credits 8
- (c) Skill Enhancement Courses (SEC) : Total Credits 9
- (d) Value Added Courses (VAC) : Total Credits 6
- (e) Internship : Credit 4

A brief description of these courses is given below.

(A) Multi-disciplinary Courses

These are 3-credit courses spanning over five different groups of subjects — (i) Natural and Physics Science, (ii) Mathematics, Statistics, and Computer Applications, (iii) Library, Information, and Media Sciences, (iv) Commerce and Management, and (v) Humanities and Social Sciences. The level of these courses is of Class XII.

Each student needs to take at any three courses, each with 3-credits from these five sub-groups during Semesters 1-3.

(Key Points: A student CANNOT choose a multidisciplinary subject, if he/she has already studied that subject during Class XI-XII. Also the subject of these courses MUST not be among the Core Subjects the student has already chosen.)

(B) Ability Enhancement Courses (AEC)

This is a 8-credit course covering Modern Indian Languages (MIL) and English Usage (Communication).

Each student needs to complete two courses of 4-credits each – one from English Usage and other from the group of MIL, especially designed for this purpose. Both these courses are split into 2-credit parts each. The **English Communication course is to be completed during the 1st and 2nd Semesters** and the **MIL course is to be completed during 5th and 6th Semesters**.

(C) Skill Enhancement Courses (SEC)

These are various skill courses with total credit allocation of 9. All students need to complete three Skill Courses, each with 3 credits, in Semesters 1, 2, & 3.

(D) Value Added Courses (VAC)

The VAC courses will come from four sub groups — (i) Understanding India, (ii) Environmental Science, (iii) Digital and Technological Solutions, and (iv) Health & Wellness, Yoga Education, Sports, and Fitness. All together they will have a credit allocation of 6.

Each student will have to take any three courses, each of 2-credits, from any three groups during Semesters 1, 3, & 4. Here one course from the **Environmental Science** group is *compulsory* except if the student takes a core course on Environmental Science.

(E) Internship

All students are to carry out an Internship with a credit allocation of 4. The internship can be carried out in any semester during Semesters 3-6. As internships are meant to be done during semester breaks, they will *not* interfere with other classes.

Progression and exits

The progression and exits during the whole course structure is given below.

(a) After 1 Year

One can exit just after one-year. In this case, the student will have to complete one extra Vocational / Skill course (Exit Course) of 4 credits and can exit the programme. The student will get a **Certificate**. The minimum total credit requirements are 44 (and 4 credits extra for the exit Vocational course).

(b) After 2 Years

One can exit the programme after two-year course as well. In this case, the student will have to complete one extra Vocational / Skill course of 4 credits and can exit the programme. The student will get a **Diploma**. The minimum total credit requirements are 88 (and 4 credits extra for the exit Vocational course).

(c) After 3 Years

If a student completes 3 years, he/she can exit the programme. In this case the student will get a **Bachelor's Degree**. The minimum total credit requirements are 120.

(d) After 4 Years

After completion of 4 years, the student gets either a **Bachelor's Degree (Honours)** or a **Bachelor's Degree (Honours) with Research**. The minimum total credit requirements are 160.

Courses of Study:

Higher Secondary Course

Two Years Higher Secondary Course (HS-Arts)
Two years Higher Secondary Course (HS-Science)

Degree Course

Four-Year Degree Programme (GU-FYUGP)

Post Graduate Courses (Self Financed)

M.A. in Assamese

Course Duration: 2 years (Four Semesters)
Course Fee : Rs.18,000/- (Per Annum)
Eligibility : Graduate in Assamese
Admission Procedure: Selection will be made on merit basis of merit list of GU.
Intake Capacity at Entry Level: 50 (Fifty)

M.A. in English

Course Duration: 2 years (Four Semesters)
Course Fee : Rs.30,000/- (Per Annum)
Eligibility : Graduate in English
Admission Procedure : Selection will be made on merit basis of merit list of GU.
Intake Capacity at Entry Level: 22 (Twenty two)





Post Graduate Diploma in Computer Application (PGDCA)

Course Duration : 1 Year
Course Fee : Rs. 6,000/- (Per Semester)
Eligibility : Degree in any discipline
Intake Capacity at Entry Level : 25 (Twenty Five)
For further information contact : **Dhrubajyoti Mishra**
Contact No.: 9707151881

Self Financed Courses in Degree in a Discipline:

***Bachelor in Computer Application**

Course Fee: Rs. 15,000/- (Per Annum)
For further information contact: **Dhrubajyoti Mishra**
Contact No. 9707151881

Self Financed Courses (Vocational Discipline):

***Bachelor of Vocation**

A. Information Technology

Course Fee : Rs. 15,000/- (Per Annum)
For further information contact: **Dhrubajyoti Mishra**
Contact No.: 9707151881

B. Physical Education

Course Fee: Rs. 20,000/- (Per Annum)
For further information contact: **Diganta Talukdar**
Contact No. 8402085787

(*For details see the subsequent pages)

Opportunities in Distance Learning:

A. G.U-Centre for Distance & Online Education:

Nalbari College Centre:

For Details please contact CDOE Office, Nalbari College, Nalbari
Coordinator: Pulakjyoti Talukdar
Contact No.: 9435323012
Office Assistant: Mitupan Deka
Contact No: 9085880080

B. Krishna Kanta Handique State Open University (KKHSOU):

Nalbari College Centre

Courses Offered

Post Graduate Programmes:

Assamese, English, Education, Sociology, Economics, Political Science.



Diploma Courses:

Diploma in Library Science

Diploma in Journalism and Mass Communication

Under Graduate Courses:

Assamese, English, Education, Economics, Political Science, Sanskrit, History, Adv.

Assamese, Philosophy, Mathematics, El. English.

For details, please Contact: KKHSOU Office, Nalbari College

Coordinator: Dr. Bishnu Bhattacharyya

Contact No.: 9435028531

Office Assistant: Bitu Ranjan Kalita

Contact No: 9864774680

Admission:

(A) Admission into H.S. Classes:

The date for submission of Application Form, and Admission are to be notified in the College Notice Board as well as in the College Website (www.nalbaricollege.ac.in). Students are to submit application form through **DARPAN AHSEC** Portal. The students are to check the merit list and have to take admission through college website.

(B) Admission into Degree courses (SAMARTH e Gov Portal):

A Student seeking admission for the session 2024-25 should apply as per NEP-2020 on Four Year Undergraduate Programme (FYUGP) of Gauhati University through the **SAMARTH e-Gov** portal (<https://assamadmission.samarth.ac.in>). The date for submission of Application Form, and Admission are to be notified in the College Notice Board as well as in the College Website (www.nalbaricollege.ac.in).

In addition to SAMARTH e-Gov Portal candidates must register their name in the college admission portal (nalbaricollege.co.in/)

Seats are reserved for students belonging to SC/ST(P)/ST(H)/OBC-MOBC categories as per State Government rules.

There are also provisions of seats for students having proficiency in co-curricular activities.

Original copies of certificates of proficiency in co-curricular activities and SC/ST/OBC-MOBC/BPL certificates should be uploaded/ produced at the time of admission.

The students selected must get themselves admitted within the stipulated time as mentioned in the website.

For admission into the College Hostels a separate Form should be submitted to the concerned hostel Superintendents.

Documents to upload @ Samarth Portal Assam

Students need to upload the following documents in desired formats as well as sizes to complete their application process.

1. Recent Passport Size Photograph
2. Signature
3. HSLC/ Equivalent Registration Certificate
4. HSLC/ Equivalent Admit Card
5. HSLC/ Equivalent Marksheet
6. HSLC/ Equivalent Pass Certificate
7. HS/ Equivalent Registration Certificate
8. HS/ Equivalent Marksheet
9. HS/ Equivalent Pass Certificate
10. Bank Passbook
11. Caste Certificate (As Applicable)
12. Disability Certificate (As Applicable)
13. TGL or Ex-TGL Certificate (As Applicable)

Details of Curriculum

Degree in a Stream

The complete curricula for GU-FYUGP are as follows.

Degree with Major and Minors

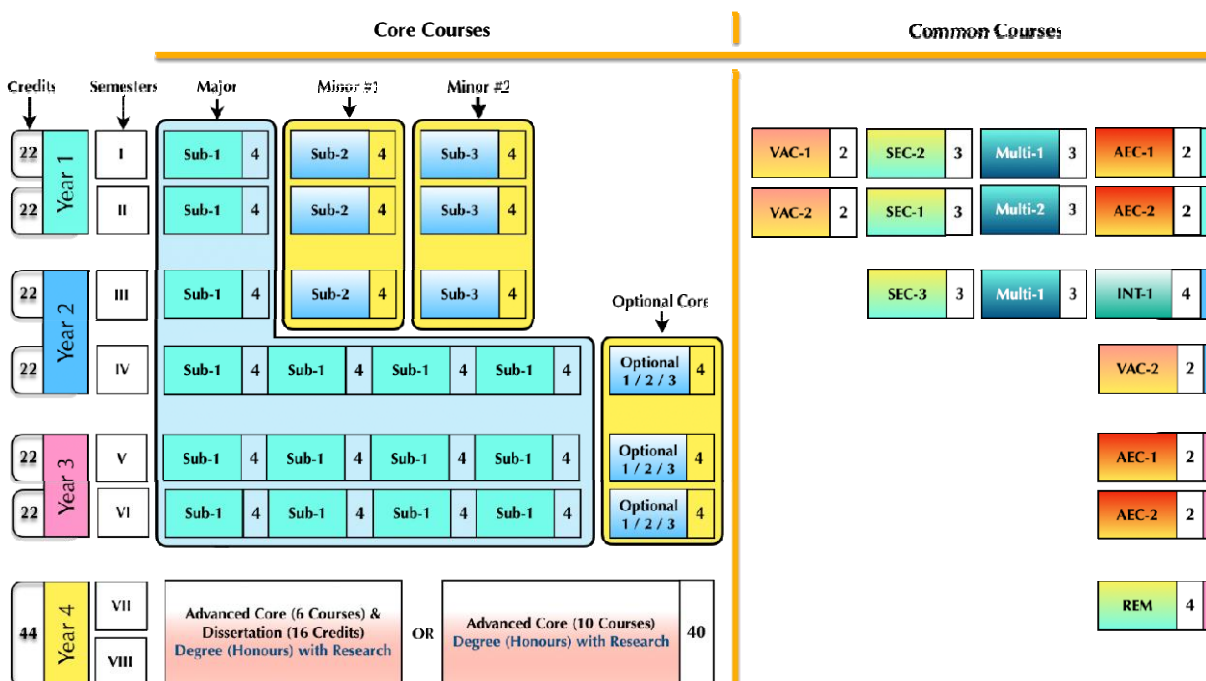

Legends

VAC – Value Added Course
SEC – Skill Enhancement Course
Multi – Multidisciplinary Course

AEC – Ability Enhancement Course
INT – Internship
REM – Research Methodology

Degree with only Minors

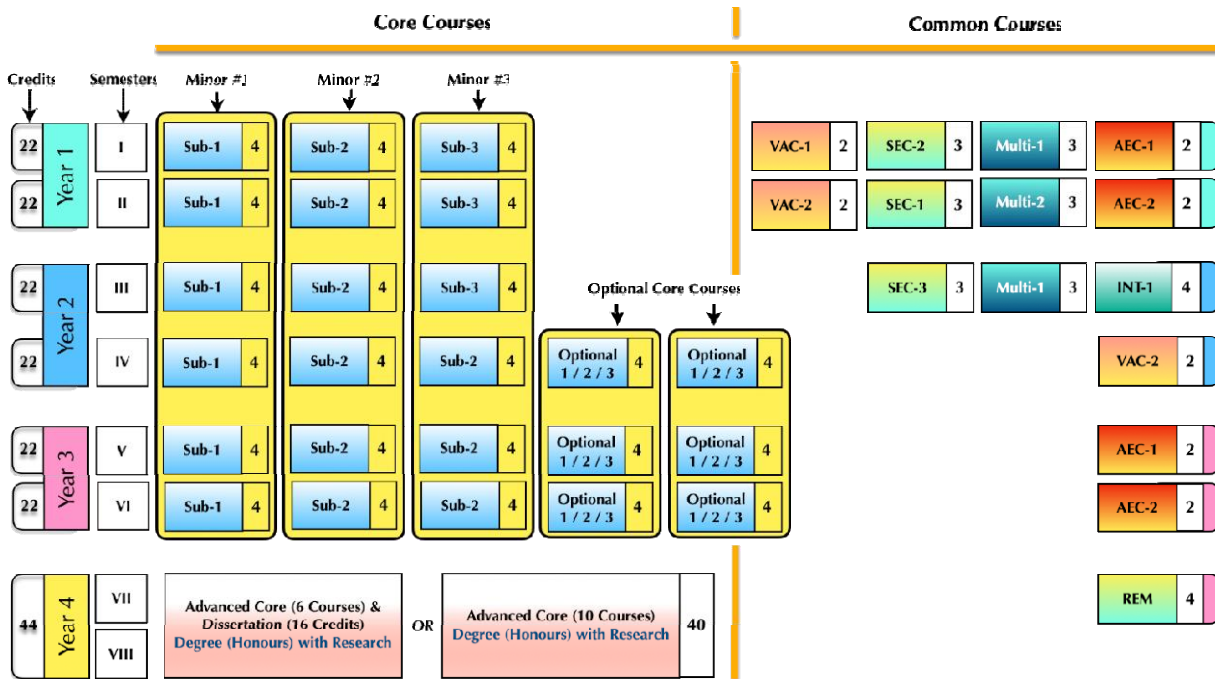

Examples

Here, we are providing two options a student can have. All the examples given below are for a 3-year degree programme.

Example 1 – Degree with Major and Minors

In this example, we show the subject distribution for a Bachelor Degree in Arts with Major and two Minors. As one can see, there are 12 **Open Core Credits** to be earned by a student above the minimum requirement of 120 credits. This open core can be utilized for any of the following:

- For another Minor
- For one of the Minor so that it can be converted to a Double Major
- To complete course from the fourth year

In the figure below, the distribution is shown visually. The papers marked in **bold-red** denote that they are compulsory. One should note that the Internship can be done in any semester within the 3rd and the 6th. As an internship is always done during a break, it essentially *does not* interfere with the semester classes.

Figure : Example #1 – Degree with a Major and two Minors.

Semester	Core #1	Courses	Credits	Core #2	Courses	Credits	Core #2	Courses	Credits	Open Core Credits	Common Credits	Total Credits
I	History	1	4	Pol Sc	1	4	Economics	1	4		10	22
II	History	1	4	Pol Sc	1	4	Economics	1	4		10	22
III	History	1	4	Pol Sc	1	4	Economics	1	4		10	22
IV	History	1+3	16							4	2	22
V	History	1+3	16							4	2	22
VI	History	1+3	16							4	2	22
	History	15	60	Pol Sc	3	12	Economics	3	12	12	36	132
	Major			Minor #1			Minor #2					

Example 2 – Degree without Major

In this example, we show the subject distribution for a Bachelor Degree in Arts without Major. The **Open Core Credits** can be utilized as described in case of Example 1.

Figure : Example #2- Degree with no Major.

Semester	Core #1	Courses	Credits	Core #2	Courses	Credits	Core #2	Courses	Credits	Open Core Credits	Common Credits	Total Credits
I	History	1	4	Pol Sc	1	4	Economics	1	4		10	22
II	History	1	4	Pol Sc	1	4	Economics	1	4		10	22
III	History	1	4	Pol Sc	1	4	Economics	1	4		10	22
IV	History	1+1	8	Pol Sc	1	4	Economics	1	4	4	2	22
V	History	1+1	8	Pol Sc	1	4	Economics	1	4	4	2	22
VI	History	1+1	8	Pol Sc	1	4	Economics	1	4	4	2	22
	History	9	36	Pol Sc	6	24	Economics	6	24	12	36	132
	Minor #1			Minor #2			Minor #3					

SUBJECT GROUPS:

STREAM: ARTS

This stream has three subject groups

1. MIL (Modern Indian Language)
2. Other Language
3. Social Science

Our College has 8 subjects in this stream, the subject groups of which and the maximum number of subjects which can be chosen from a group by a student is shown in the following table:

Arts		
MIL	Other Language	Social Science
Assamese	English	Economics*
Sanskrit		Education
		Pol. Science
		History
		Philosophy
**Max 1	**Max 1	**Max 3

STREAM: SCIENCE

This stream has four subject groups

1. Physical Science
2. Biological Science & Anthropology
3. Earth & Environmental Science
4. Computer & Information Science

Our College has 9 subjects in this stream, the groups of which and the maximum number of subjects that a student can choose from a group is shown in the following table:

Science			
Physical Science	Biological Science	Earth & Environmental Science	Computer & Information Science
Physics	Botany	Geology	Computer Application
Chemistry	Zoology	Geography	
Mathematics			
Statistics			
**Max 3	**Max 2	**Max 1	**Max 1

* Dual Stream Subject

** Maximum number of subjects that a student can choose from a group of subjects.

- **Major subjects**

The following subjects have Major as well as Minor options in our college.

Arts Stream

- **MIL**
Assamese, Sanskrit
- **Other Language**
English
- **Social Science**
Economics, Education, History, Philosophy, Political Science.

Science Stream

- **Physical Science**
Chemistry, Mathematics, Physics, Statistics
- **Biological Science & Anthropology**
Botany, Zoology
- **Earth & Environmental Science**
Geography

- **Minor subjects**

In addition to all the subjects mention under the major category a student can also have minors in the following subjects in our college.

Stream: Science

- **Earth & Environmental Science**
Geology
- **Computer & Information Science**
Computer Application

List of prerequisites & requirements

Prerequisites are conditions which need to be fulfilled prior to admission into the FYUGP. Each subject and its course (paper) have their own prerequisites fulfilled by students prior to enrollment. The requirements are conditions which need to be fulfilled when a student chooses a certain subject or course.

Following are the prerequisites for the CORE subjects of Arts & Science that have in our college at the entry level of the FYUGP i.e. at the first semester

Stream: Arts		
MIL		
Subjects	Prerequisites	Requirements
Assamese	Assamese (X-Level) for minor & (XII-Level) for Major	NONE
Sanskrit	Sanskrit in (X-Level)	

Stream: Arts		
Other Language		
Subjects	Prerequisites	Requirements
English	English (X-Level)	NONE

Stream: Arts		
Social Science		
Subjects	Prerequisites	Requirements
Economics	NONE	NONE
Education		
History		
Philosophy		
Political Science		

Stream: Science		
Physical Science		
Subjects	Prerequisites	Requirements
Chemistry	Chemistry & Mathematics (XII-level) for Major & Only Chemistry (XII-Level) for minor	NONE
Mathematics	Mathematics (XII-Level)	NONE
Physics	Physics & Mathematics (XII-Level)	MATHEMATICS
Statistics	Mathematics (XII-Level)	NONE

Stream: Science		
Biological Science		
Subjects	Prerequisites	Requirements
Botany	Biology (XII-Level)	Chemistry
Zoology	Biology & Chemistry (XII-Level)	Chemistry

Stream: Science		
Earth & Environmental Science		
Subjects	Prerequisites	Requirements
Geology	Science (XII-Level)	NONE
Geography	NONE	

Stream: Science		
Computer Science		
Subjects	Prerequisites	Requirements
Computer Application	NONE	NONE

Degree in a Discipline

The GU-FYUGP has quite a couple of subjects, where 'Degree in a Discipline' is offered. These also include all vocational courses. It has the same FYUGP structure – i.e. Core Courses with a minimum of 84 credits and Common Courses credits of 36 (in a 3-year programme) having no Majors or Minors.

List of disciplines in Our College

1. Computer Application

Bachelor's in Computer Application

Vocational Disciplines

1. Information Technology
2. Physical Education

These subjects are Vocational Subjects, where the degree awarded is Bachelor's Degree in Discipline (Vocation).



NAAC PEER TEAM VISIT, April 2019

Seat capacity for Bachelor's Degree in a Stream (B.A./B.Sc.)

Subject wise Major and Minor Courses:

Sl. No.	Course	Major	Minor
1	Assamese	50	170
2	*Botany	40	110
3	Chemistry	40	140
4	Computer Application	----	45
5	Economics	60	160
6	Education	40	180
7	English	60	160
8	Geography	Sc - 05 & Arts - 35	Sc - 15 & Arts - 125
9	Geology	---	65
10	History	40	170
11	Mathematics	40	130
12	Philosophy	50	170
13	Physics	40	120
14	Political Science	50	170
15	Sanskrit	50	90
16	Statistics	40	60
17	*Zoology	40	110

NB:- As per available seat capacity a student have to choose any three subjects either from subject groups of Arts stream or Subject groups of Science Stream.

*As per subject requirements and available seat capacity a student choosing Botany as Major or Minor course must choose Chemistry & Zoology, Similarly a student choosing Zoology as Major or Minor Course must choose Chemistry & Botany.

Seat capacity for Bachelor's Degree in a Discipline

Sl. No.	Course	Seat Capacity
1	Computer Application (Bachelor's of Computer Application) (Self Financed)	30

Seat capacity for Bachelor's Degree in Vocational Discipline

Sl. No.	Course	Seat Capacity
1	Information Technology (Self Financed)	30
2	Physical Education (Self Financed)	30

Subject Combination For H.S Students

COMPULSORY SUBJECTS

1. MIL (Assamese /Alternative English)
2. English

Subject combination for H.S. (Sc.) Students:

Any one of the following combinations

Physics//Chemistry//Mathematics//Biology
--

Physics//Chemistry//Mathematics//Statistics

Physics//Chemistry//Mathematics// Computer Science & Application (CSCA)

Subject combination for H.S. (Arts) Students:

Any four of the following subjects:

Political Science

Logic & Philosophy

Economics

History

Adv. Assamese/Sanskrit

Computer Science & Application (CSCA)

Geography

Mandatory Announcement To All Applicants:

- *Students applying for B.A/B.Sc. in Nalbari College, Nalbari are required to opt either Major with Minor Programme or Minor programmes with no Major. Admission to any Programme is subject to availability of seats.*
- *Subject Combination Once Offered is Unalterable.*

Hostel Facility:

The College has one Girls Hostel within the campus. Hostel seats are allotted at the time of admission on the basis of merit. Application for Hostel admission is to be made to the Hostel Superintendent in the prescribed form. Every boarder must observe the Hostel Rules Strictly. Violation of these rules may cause expulsion. Boarders are allowed to meet the visitors on the visiting day during visiting hours only.

Hostel Superintendent: Dr. Subrata Barman, Associate Professor, Economics (M-9435027959)

T.N.G. Library:

The Central Library of Nalbari College is named after 'TRAILOKYA NATH GOSWAMI' the founder Principal of the College in recognition of his erudition and distinguished services to the College. The TNG Library is a registered member of N-LIST programme of INFLIBNET. Recently a Digital Library Section has been started; it will also serve as an E-resource centre. Wi-Fi connection in the college campus has been started too. The total area of the Library is 515 sqmtr.(5544 sq. ft.) with a total Seating Capacity of 139.

Collection: The Library of this college has a very rich collection in various subjects and tries to provide the users with the best sort of qualitative and quantitative documents that can be done with the available financial sources and supports.

Total Collection (Text Books & Reference)	70000+ (As per Accession Register)
Magazines	16+
Journal	16+
Newspaper	12+
E-Journals	6000+
E-Books	100000+

* e-Books, e-Journals and Digital Databases are accessed from INFLIBNET N-LIST databases.

Besides this, all departments have Departmental Libraries providing immense help to students in their academic pursuits.

Services & Facilities:

i) Reading Room, ii) Computerized Circulation, iii) OPAC, iv) N-LIST, v) Open Access Journal, vi) Reprographic Service, vii) Departmental Library service, viii) Suggestion Box, ix) User Orientation x) Information Display/ News / Notice Board. xi) Internet Access xii) Wi-Fi Facility xiii) Reference Service

Number of books issued:

Working Hours:

H S: 2 books for 15 days

TDC: 2 books for 15 days

P G: 2 books for 15 days

Faculty members: 20 books for 90 days

On working days : From **9:30 AM to 5:30 P.M.** On Holidays :
Closed

General Library Rules:

Before entering the library, books (not belonging to the Library), all sorts of bags, umbrellas, packets etc. are to be deposited in the property counter.

A member will have to show the Membership Card/Identity Card/Gate Pass at the entrance whenever he/she wants to enter the Library.

Before entering the Library the Gate Register is to be signed legibly.

Books treated as 'Reference' and 'Rare' are not issued on loan. Journals and periodicals will not be issued. Books on loan with members can be recalled by the Librarian at any time.

Borrowers must satisfy themselves about the physical condition of the book before borrowing, otherwise they will be held responsible for any damage or mutilation noticed at the time of returning.

An overdue charge of Re 1. for a book per day shall be levied on a member, if a book is kept beyond the period of loan. The period of loan can be extended by the Librarian, on individual cases. The overdue fines may be reduced or waived by the Librarian on very special cases only.

If a borrower fails to return a book borrowed by him/her or if the book is found to be damaged or mutilated he/she will be required to either (a) replace the book with a new copy or (b) pay Ten times on the publisher's price of the book.

While borrowing book/s, a student member must produce his/her Identity Card at the Issue Counter. The Membership Card is not transferable.

Overwriting on the Membership Card is not permissible.

In no case the expiry date of student Membership Card shall be extended.

If the Membership Card gets lost or mutilated because of use or otherwise, it should be reported to the Librarian immediately. A duplicate Membership Card will on prayer be issued on payment. The member, however, will continue to be responsible for any loss which the Library may suffer through the loss or misuse of the Card.

Students are to return books within two week time immediately after their final examination is over, failing which they will be declared library defaulter.

Students of science classes are to return books within three days after their practical examination are over, failing which they will be declared library defaulter.

Teachers, officers and employees of the College shall have to take Library Clearance Certificate before they take release from this College to join other institution or get retired from this College.

Departmental libraries are to borrow books against the Pass-Book issued against each of the Department. At the time of change of Headship of the department, the outgoing Head will hand- over the Departmental Library Pass-Book with details of books to the next Head of the Department.

Academic Session:

The Academic session of the College usually begins in August with Summer Recess in July, Autumn Recess in September/October and winter recess in December/January.

Medium of Instruction:

In general the medium of instruction up to degree course is Assamese and English. But the medium of instruction in Major subjects is English except the Assamese Major and P.G. Course in Assamese.

College Uniform:

In Summer: Boys'- Parrot Green Shirt and Black Trousers.

Girls' - Parrot Green Kurti and Black Salwar and Dupatta.

In winter: Same as above with Black Blazer/Sweater for Boys and Girls

Examination and Attendance:

In case of H.S. course, a student must pass the first year examination for promotion to the second year class. The result of first year examinations is declared by the College and that H.S. Final Examination declared by Council.

The Sessional/Preparatory Examinations are conducted by the College. As per Gauhati University guideline, the marks of Internal Assessment would include marks of sessional examination, attendance of the student and home assignment/seminar presentation. Attendance in all examination of the College (Sessional/unit test/preparatory) are mandatory. Students failing to appear in any College exams for some unavoidable circumstances are to inform the College authority immediately and are to sit in specially arranged exams notified by the Examination Board of the College.

Students having less than 75% attendance of the classes taught in a academic year shall be declared as Non-Collegiate and Will be debarred from contesting college election.

Will be allowed to sit for the examination only on payment of a fine.

Students having less than 60% of attendance will be declared as dis-collegiate and will be debarred from appearing in the examinations.

Identity Card:

A non-transferable identity card with bar code is issued to each student in the beginning of every academic session. All the students shall wear their identity cards, well displayed. Any teaching or non teaching staff shall have the right to verify it. Duplicate identity card is issued in case of loss or damage of the original card, on payment of identity Card fee. A student who is awarded a scholarship must produce his/her identity card at the time of drawing scholarship.

College Transfer Certificate:

A student should apply to the Principal for transfer certificate with the clearance certificates from College office, Library, N.C.C., Superintendent of Hostel and record of percentage of attendance from the respective Head of the Departments.

Facilities and Students Welfare Services of the College:

The College is equipped with separate departmental common rooms for each department, laboratories for science departments, a Network Resource Centre (NRC) with internet connectivity, hostel facility for girls, a huge play ground flanked with pavilion, a computer lab, two sets of generator for uninterrupted power supply, a Conference Room, a library with separate reading rooms for faculty for boys and girls students, canteen for Students and teachers. These facilities surely constitute the strength of the institution. All Science departments are equipped with LCD projectors, and various sophisticated instruments for experiments and other laboratory uses. Besides, a sophisticated digital classroom has been constructed with financial assistance from the Government of Assam. The campus of the College is Wi-Fi enabled and under strict CC TV surveillance. The College has vibrant units of both NCC and NSS. The cadres of both the units have brought laurels to the institution at regional and national levels.

Students Union:

Nalbari College Students Union (NCTU) is a vibrant forum of students of this institution. It is an annually elected general body of students which monitors and represents the interest of the students of the College. It also provides welfare support to the community where and when necessary. The membership of NCTU is compulsory for every student.

College Magazine and other Creative Activities:

The College regularly publishes its magazine 'Nalbari'. This magazine offers a platform for the interested students to explore their literary talent. Besides the college magazine, each academic department of the college regularly publishes their wall magazines.

Students Mutual Aid Fund:

For each academic session the college generates a fund viz. Student's Mutual Aid Fund. This fund provides financial assistance to meritorious but economically deprived students. To avail financial aid from this fund students are to apply in a prescribed Application Form available at the college office. Each application should be accompanied with income certificate of the parents from competent authority. A committee is appointed to scrutinize the application and to prepare the list of deserving candidates.

Career and Counseling Cell:

The Career and Counseling Cell of the College is actively pursuing its objective of providing career information and guidance to the students. Various workshops and seminars are organized periodically for sensitizing the students about their career opportunities in different dimensions. Moreover this information is regularly updated on the display board of the cell.

Scholarship:

The following scholarships are sponsored by the State and Central Governments.

Central Sector Scheme (<http://www.cbse.nic.in/Scholarship>)

Combined Merit Scholarship

(<http://www.dheassam.gov.in/scholarship.asp>) INSPIRE Fello

(<http://www.inspire-dst.gov.in/fellowship.html>)

(Ishan Uday Scholarship (For North Eastern Region)

(<http://www.ugc.ac.in/ner/>) Means cum Merit Scholarship

(<http://www.dhescholarship.org.in>)

Minority Scholarship (<http://www.momascholarship.gov.in/>)

Post Metric Scholarship for SC, ST & OBC (www.dheassam.gov.in)

Students Mutual Aid Fund Scholarship (College Sponsored)



Study Tours:

To provide our students with much needed exposure to quality national and international labs, institutions, libraries, industries and museums, various academic departments of the college annually organize study tours to different parts of the country.

Canteen:

The College authority has recently constructed two spacious and well furnished canteen for the students, teachers and the employees of the college. A committee comprising of teachers supervise the cleanliness and hygiene of the canteen.

N.C.C.

The College has a full-fledged N.C.C. Unit and willing students are imparted necessary training to develop leadership qualities, spirit of patriotism and self confidence. The present in-charge of NCC is Lt. Anjanjyoti Sarma, Assistant Professor, Department of B.P.E.

N.S.S.

Nalbari College has the National Service Scheme (N.S.S.). It provides opportunities to students to develop their personality through community service. N.S.S. camps are organized by the N.S.S. unit of the College. The present in- charge of N.S.S. is Dr. Ratan Deka, Assistant Professor, Department of English.

Grievance Redressal Cell

The College has a Grievance Redressal Cell comprising of senior faculty members for objective and effective redressal of the grievances of the students.

Add-On Courses:

19 Add-On/Certificate Courses

Teaching and Learning at Nalbari College

Our Academic Departments:

Faculty of Arts

Department of Assamese

The Department of Assamese was established in 1945, the year of foundation of the college. Late Iswar Ch. Baruah rendered service as the Head of the Department. Renowned litterateur and the recipient of prestigious Sahitya Academy Award Trailokya Nath Goswami, the founder Principal of the college also devoted his time in guiding the students of the department. The reputation of the department was further enhanced by the resourceful teaching of the eminent thinkers and scholars like Sashi Nath Sarma, Dr. Basanta Kr. Bhattacharyya, Harendra Nath Sarma and the like. The major course at the degree level was introduced in 1962. The PG course in the department was started in 1986 and later on regularized under Gauhati University in 1993. Semester system was introduced in the year 2001. The department is equipped with a departmental seminar library with approximately two thousand valuable books and more than two hundred magazines for the use of Post Graduate students. The department can boast upon consistent brilliant result in both UG and PG level. The present faculty of the department includes:

- Pankaj Dutta Baruah, M.A. (Double), Associate Professor(M-9954664080)
- Dr. Bandana Das, M.A. (Double), M. Phil., Ph. D., Associate Professor and HOD(M-9864274405)
- Dr. Juri Hazarika, M.A., Ph D, Assistant Professor (M-9854206012)
- Ms. Punyashri Bezbaruah, M.A., Assistant Professor (M-9401232090)

Contractual for PG Course in Assamese

- Bhaskar Bhatta (Contractual Faculty)
- Banti Sarma (Contractual Faculty)

Department of Economics

The department was established in 1962. Initially the department was a part of the Department of Civics which was a combination of Economics and Political Science. Prof. Uma Kanta Sarma was the founder HOD. The department is best known for its brilliant result. Besides good track record of consistent bright result, it had proudly produced the university topper in Economics. The present faculty of the department includes:

- Dr. Subrata Barman, M.Sc., Ph.D., Associate Professor (M-9435027959)
- Dr. Bishnu Bhattacharyya, M.A., Ph. D, Associate Professor and HOD (M-9435028531)
- Dr. Aditi Das, M.A., Ph. D., Assistant Professor (M-9954715244)
- Rintu Deka, M.A., M. Phil., Assistant Professor (M-9508406100)

Department of English

The Department of English was established in the year of inception of the College under the headship of founder Principal and eminent scholar Trailokya Nath Goswami. The Major Course at the degree level was started in 1966. It is worth mentioning that the department was blessed with the invaluable services of renowned scholars like Ashok Mukharjee, Kuber Nath Roy, Nirupama Bargohain, Abul, Lais and Haridutta Sarma. The present faculty of the department includes:

- Dr. Kakali Dutta, M.A., Ph.D., Associate Professor (M-9435115491)
- Dr. Ranjana Bhattacharyya, M.A., Ph.D., Associate Professor (M-943535660)
- Dr. Ratan Deka, M.A., M. Phil., Ph. D., Assistant Professor and HOD (M-9854304499)
- Dr. Darshana Goswami, M.A., Ph.D., Assistant Professor (M-9859213563)
- Ms. Gracy Lalmswam Khobung, M.A., Assistant Professor (M-9127372640)

Contractual/Guest faculty for PG Course in English

- Pragati Barman, M. A. Assistant Professor (Contractual Faculty) (M-9678556263)
- Nilanjana Sarma, M. A. Assistant Professor (Contractual Faculty) (M-8812004489)

Department of Education

Education was introduced as a subject in TDC General Course in 2015 to cater to the needs of large number aspirants. The present faculty of the department includes:

- Kakali Sarma, M.A., Assistant Professor (Contractual Faculty) (M-6001612916)
- Karabi Deka, M. A., Assistant Professor (Contractual Faculty) (M-9101129228)

Department of Geography

The Department was established in 1954. Initially it was designated as Commercial Geography. In 1972, it became a separate discipline as Geography. In 1984, it was included in degree general course and the major at degree level was introduced in 1987. Prabodh Ch. Goswami was the founder HOD. The GIS Lab and the departmental Museum are the marked features of the department. The present faculty of the department includes:

- Phatik Ch. Barman, M.A., Associate Professor (M-7577034754)
- Hitesh Thakuria, M.A., M. Phil., Assistant Professor (M-9854270015)

- Dr. Binita Devi, M. A., M.Phil., Ph. D., Assistant Professor and HOD (M-9954854709)
- Dr. Darsana Sarmah, M.A., Ph. D., Assistant Professor (M- 9854030075)
- Riki Deuri Bharali, M.A., M.Phil., Assistant Professor (M- 9706769804)

Department of History

The Department was established in 1945. The founder HOD was Prabhat Ch. Goswami who was a renowned scholar and one of the most prominent founder figures of the college. He also shouldered the responsibility of Principal after T. N. Goswami. The department was further graced by the presence of scholars like Munindra Chakravarty and Nagendra Nath Acharya. Major course at the degree level was started in 1969. The main strength of the department is its consistent result and a healthy teacher-learner relationship. The department has been organizing an Academic Lecture for last few years. The present faculty of the department includes:

- Pulakjyoti Talukdar, M.A. Associate Professor (M-9435323012)
- Dr. Pradyumna Sarma, M.A. Ph.D., Associate Professor and HOD(M-9435027960)
- Sachindra Kalita, M.A., M. Phil., Assistant Professor(M-9859950339)
- Pranita Barman, M.A., M. Phil., Assistant Professor(M-9435018413)

Department of Philosophy

The department is an integral part of Nalbari College. Establish in 1951 the department introduced major course in 1982. Noted poet philosopher Bhabananda Dutta was the founder HOD of Philosophy. Further, the department was blessed by the teaching of reputed professors like Jagannath Chakravarty and Keshab Ch.Talukdar.

- Purabi Talukdar, M.A., M. Phil., Assistant Professor and HOD(M-9864333638)
- Mr. Sony Das, M.A., Assistant Professor (M-8474040098)
- Ms. Simi Borgohain, M.A., Assistant Professor (M-9854810873)
- Manomati Deka, M.A., Assistant Professor (Contractual Faculty) (M-9365657926)
- Rajasri Goswami, M.A., Assistant Professor (Contractual Faculty) (M-8638732502)

Department of Political Science

The department was established in 1945. Initially the department was a part of the Department of Civics which was a combination of Economics and Political Science. Prof. Uma Kanta Sarma was the founder HOD. Major course was introduced in 1962. Political Science being one of the most sought after subjects at the degree level, the department attempts to provide resourceful and dedicated services to the young learners. The present faculty of the department includes:

- Dr. Rahul Daimary, M.A., Assistant Professor and HOD(M-9085224890)
- Dr. Binoy Mushahary, M.A., Assistant Professor(M-9854633120)
- Dr. Deepak Km. Gogoi, M.A. Ph. D, Assistant Professor(M-7896196466)
- Kaberi Dutta, M.A., M. Phil., Assistant Professor(M-9864315379)

Department of Sanskrit

The Department of Sanskrit was established in 1945 and the major course was introduced in 1971. The founder HOD of the department was Lakshi Kanta Tripathi. Veteran Sanskrit scholar like Mukunda Madhav Sharma, Bhagawan Goswami and Jamini Kanta Sarma graced the department. The department has a very consistent record of brilliant result. The student of this department clinched the laurel of Best Graduate of Gauhati University for three times. The present faculty of the department includes:

- Dr. Mani Sarmah, M.A. M. Phil., Ph.D. Vyakaran Sastri, Associate Professor (M-9435310553) (on Lien)
- Dr. Goutam Choudhury, M.A., M. Phil., Ph. D, Vyakaran Sastri, Assistant Professor and HOD (M-9859976950)
- Dr. Rupsmitta Bujarbaruah, M.A., Ph. D., Assistant Professor(M-9864076252)
- Vacant

Faculty of Science:

Department of Botany

The department of Botany was established in 1960 and the major course was introduced in 1987. Prof Hem Chowdhury was the founder HOD of Botany. The department has a Botanical Garden and a well equipped Laboratory The present faculty of the department includes:

- Dr. Gunajit Kalita, M.Sc., Ph. D, Assistant Professor (M-9435346728)
- Dr. Namita Deka M.Sc., M. Phil., Ph. D., Assistant Professor & HOD (i/c) (M-8486944267)
- Ms. Dhritashri Das M.Sc., Assistant Professor(M-8638153433)
- Dr. Rupak Kr. Sarma, M.Sc., Ph. D., Assistant Professor(M-9401182318)

Department of Chemistry

The department of Chemistry traces back its root to 1958. Prof J. N. Negi rendered his service as the founder HOD of the department. The Major course was introduced in 1971. Chemical Society of the Department is an active forum which has been organizing two lectures each year by inviting prominent personalities in the field of Chemical sciences since 2013. The Department is co-coordinating with Association of Chemistry (ACT), Mumbai in holding various events such as CONTECH test, Global Women's Breakfast etc. The present faculty of the department includes:

- Dr. Dhiraj Talukdar, M.Sc., Ph. D., Associate Professor, Coordinator IQAC, (M-9435028189)
- Dr. Nabajyoti Deka, M.Sc., Ph. D., Associate Professor and HOD (M-9864493195)
- Dr. Dhanju Mani Pathak, M.Sc., Ph. D, Associate Professor (M-9864503214)
- Dr. Rupam Sarma, M.Sc., Ph. D, Assistant Professor(M-9435492089)
- Dr. Purabi Sarmah, M.Sc., Ph. D, Assistant Professor (M-9864721924)
- Dr. Pranita Bora, M.Sc., Ph. D, Assistant Professor (M-8638506854)
- Vacant

Department of Geology

The Department of Geology has recently been introduced in Nalbari College in 2013 to cater to the needs of large number aspirants. The department has established a Geological Lab for the benefit of the student. The present faculty of the department includes:

- Rituparna Barman, M.Sc., Assistant Professor (Contractual Faculty) (M-8486882211)

- Dr. Bandeepta Medhi, M.Sc., Ph. D., Assistant Professor (Contractual Faculty) (M-9854144133)

Department of Mathematics

The Department of Mathematics was established in 1945 and the founder Head of the Department was Kamakhya Kamal Pondit. The major course was introduced in 1973. The department can boast upon its brilliant academic result. The present faculty of the department includes:

- Dr. Piroja Begum, M.Sc., M. Phil., Ph.D., Associate Professor and HOD(M-9687305399)
- Gautam Sarma, M.Sc., M. Phil., Assistant Professor(M-9864382547)
- Dr. Mriganka Sekhar Dutta, M.Sc., Ph. D., Assistant Professor(M-9957976864)
- Rownak Kundu, M.Sc., Assistant Professor(M-7002333571)

Department of Physics

The Department of Physics was established in 1958 and the major course was introduced in 1975. Prof. Prabhat Chandra Sarma was the founder HOD of Physics. The Physics Forum of the Department is an active forum which has organized various lectures and specially Sky Observation Programme from time to time. The present faculty of the department includes:

- Dr. Hangshadhar Rajbongshi, M.Sc., Ph. D, Associate Professor (M-9435323380)
- Ananta Rajbongshi, M.Sc., M. Phil., Assistant Professor and HOD (M-9707370058)
- Surajit Sarma, M.Sc., M. Phil., Assistant Professor(M-7578998948)
- Dr. Nipan Mazumdar, M.Sc., Ph. D., Associate Professor(M-9864290835)
- Dr. Hemen Kakati, M.Sc., Ph. D., Assistant Professor(M-9864145217)
- Dr. Dhruba Jyoti Gogoi, M.Sc., Ph. D., Assistant Professor(M-9678995085)

Department of Statistics

The Department of Statistics was started in 1982 under the headship of Prof. Pranab Choudhury. The Major Course was introduced in 2014. The present faculty of the department includes:

- Dr. Bhupen Kr. Nath, M.Sc., Ph. D., Assistant Professor and HOD (M-8876213478)
- Dr. Anamika Dutta, M.Sc., Ph. D., Assistant Professor (M- 8638550295)
- Vacant
- Darshana Barman, M.Sc., Assistant Professor (Contractual Faculty) (M-8011939604)
- Kapil Pathak, M.Sc., Assistant Professor (Contractual Faculty) (M-8486818074)

Department of Zoology

The Department of Zoology was started in 1966 and the major course was introduced in 1978. Prof Anil Kumar Srivastava served the department as the head from its inception. A well equipped field laboratory and a small fishery are the special features of the department. The present faculty of the department includes:

- Kumud Ch. Rabha, M.Sc., M. Phil., Assistant Professor and HOD (M-9435726210)
- Dr. Mitali Deori, M.Sc., Ph. D., Assistant Professor (M-9864869562)
- Dr. Bidyut Kr. Das, M. Sc., Ph. D., Assistant Professor (M-8761880021)
- Dr. Dibashree Tamuli, M.Sc., Ph. D., Assistant Professor (M-8800941876)
- Banashree Sarma, M.Sc., Assistant Professor (Contractual Faculty) (M-7399590802)

Department of Computer Science:

The department of Bachelor of Science in Information Technology (B. Sc.-IT), Nalbari College was established in the year 2013 with the aim of to spread the knowledge of computer to common people and give a better environment to grow up along with current technologies. The present faculty of the department includes:

- Dhruva Jyoti Mishra, MCA, Assistant Professor(Contractual Faculty) (M-9707151881)
- Ankur Baishya, MCA, Assistant Professor (Contractual Faculty) (M-9864698734)
- Hirak Jyoti Barman, MCA, Assistant Professor(Contractual Faculty) (M-9706830861)
- Pranjal Dutta, M.Sc. (IT),Assistant Professor (Contractual Faculty) (M-8721872320)

Department of Physical Education:

- Diganta Talukdar, M. P. Ed., Assistant Professor(Contractual Faculty) (M-7002884988)
- Anjanjyoti Sarma, M. P. Ed., Assistant Professor(Contractual Faculty) (M-8638695075)

Computer Application:

Computer Application is a vocational subject approved by Gauhati University. This subject was introduced in Nalbari College in 1993. The subject offers a very future ready IT package for all degree students not opting for any major subject in degree level. The present faculty of the department includes:

- Karabi Das, M.Sc. E&T, Assistant Professor (Contractual Faculty) (M-8638196204)

Environmental Studies:

Environmental Studies is a compulsory subject for both B.A. and B. Sc. 3rd and 4th Semester.

- Giren Ch. Deka, M.A. Assistant Professor (Contractual Faculty) (M -9864524355)

Trailokya Nath Goswami Library Staff:

<u>Sl. No</u>	<u>Name</u>	<u>Designation</u>
1	Dr. Ranjanjyoti Sarmah, M.L.I.Sc., Ph.D.	Librarian
2	Mrs. Barnali Parashar, M.L.I. Sc., PGDCA	Assistant Librarian
3	Mr. Jamuna Chakravarty, B.A	Sr. Assistant
4	Mr. Parthapratim Sarma, M.Sc., PGDCA, DLIS, BLIS	Library Assistant
5	Mrs. Banashree Barman, B.A	Technical Assistant (Contractual)
6	Mr. Champak Barman	Library Bearer
7	Mr. Pulakesh Barman	Library Bearer (Contractual)



College office and Non-Teaching Staff Grade-III

<u>Sl.</u>	<u>Name</u>	<u>Designation</u>
1	Mr. Manoj Kr. Das., M.Com. D.LIS	Sr. Asst. & Head Asst. i/c
2	Mr. Binod Chandra Dutta, B.A	Lab. Asst.
3	Mrs. Madhabi Lata Devi, B.A	Jr. Asst.
4	Mr. Mitupan Deka, M.A	Jr. Asst.
5	Mr. Bitu Ranjan Kalita, M.A	Jr. Asst.
6	Mr. Mantu Das, M.A.	Jr. Asst.
7	Mr. Biswajit Baishya, M.Sc	Jr. Asst.
8	Mr. Partha Pratim Bharadwaj, M.A	Jr. Asst. (Contractual)
9	Mr. Prabodh Deka, H.S L.C	Jr. Asst. (Contractual)
10	Mrs. Anupama Kalita, B.A., PGDCA	Lab. Asst.(Contractual)
11	Mr. Sapratibh Upanasa, M.Sc., PGDCA, D.El.Ed.	Jr. Asst. (Contractual)

College office and Non-Teaching Staff Grade- IV

<u>Sl.</u>	<u>Name</u>	<u>Designation</u>
1	Mr. Sanatan Barman	Office Peon
2	Mr. Haren Rabha	Office Peon
3	Mr. Paresh Barman	Office Peon
4	Mr. Pranjit Barman	Office Peon
5	Mr. Arun Kalita	Lab. Bearer, Chemistry
6	Mr. Kailash Barman	Lab. Bearer, Chemistry
7	Mr. Kankan Barman	Lab. Bearer, Chemistry
8	Mr. Ratneswar Barman	Lab. Bearer, Zoology
9	Mr. Hitesh Kalita	Lab. Bearer, Zoology
10	Mr. Ramen Kalita	Lab. Bearer, Zoology
11	Mr. Chakreswar Barman	Lab. Bearer, Botany
12	Mr. Manoj Haloi	Lab. Bearer, Botany
13	Mr. Satish Deka	Lab. Bearer, Botany (Contractual)
14	Mr. Kamal Kalita	Lab. Bearer, Physics
15	Mr. Diganta Das	Lab. Bearer, Physics
16	Mr. Kishor Kr. Dutta	Lab. Bearer, Physics
17	Mr. Pankaj Bezbaruah	Lab. Bearer, Geography
18	Mrs. Kanika Rabha	Lab. Bearer, Geography
19	Mr. Ramesh Baishya	Bearer, English and Philosophy (Contractual)
20	Mr. Sadananda Talukdar	Bearer, Assamese, CAP, Edu (Contractual)
21	Mr. Chandan Deka	Bearer, Pol. Science, Economics, History (Contractual)
22	Mr. Chintu Barman	Bearer, B.Sc IT, BPE, Sanskrit (Contractual)
23	Mr. Bikash Das	Bearer, Statistics (Contractual)
24	Mrs. Bhatima Barman	Nurse (Contractual)
25	Mrs. Rumi Devi	Cleaner
26	Mrs. Rina Kalita	Cleaner
27	Mrs. Anita Barman	Cleaner
28	Mrs. Rina Das	Cleaner
29	Mr. Dilip Das	Security Guard
30	Mr. Srikanta Barman	Night Chowkidar
31	Mr. Dilip Mazumdar	Night Chowkidar
32	Mr. Dino Barman	Night Chowkidar

Occasions	Tentative date
Fresher's Social	Last week of September
NSS Day	24 th September
PNC debate	3 rd week of September
College Election	1 st week of October
Death Anniversary of Dr. Bhupen Hazarika	5 th November
Joint meeting of Parents & Teachers	1 st week of November
NCC Day	23 rd November
Republic Day	26 th January
Saraswati Puja	January/February
College week	Last week of January
Joint meeting of Alumni & Staff	1 st week of February
VP's special programme	3 rd week of February
Science Day	28 th February
TNG Memorial Lecture	3 rd week of March
Inter District Quiz Competition	1 st week of April
Parting Social	3 rd week of April
World Environment Day	5 th June
Foundation Day	4 th July
Independence Day	15 th August



Students' Code of Conduct and Disciplinary Processes

Nalbari College, Nalbari stresses in maintaining a healthy social and educational atmosphere in its campus. Students are expected to be honest in their behavior and responsible towards the society. While enjoying individual freedom they must not hamper freedom of others. In this regard the Code and Conduct for Student's outlines student conduct and disciplinary policies that pertain to students and student organizations at Nalbari College. It is designed to provide information to students, faculty and staff regarding the ideals that underlie our academic mission, and the expectations that the Institute nurture regarding the conduct of students.

The following considerations constitute the code of student conduct for Nalbari College, Nalbari:

Any student, individually or as a member of a group involved in any unacceptable social behavior on or off campus shall be subject to disciplinary actions by the Students' Code of Conduct Committee.

Students having less than **75% attendance** of the classes taught in a academic year shall be declared as Non-Collegiate and Will be debarred from contesting college election.

Will be allowed to sit for the examination only on payment of a fine.

Students having less than 60% of attendance will be declared as Dis-collegiate and will be debarred from appearing in the examinations.

A student who is absent for 15 consecutive days in the beginning of the academic session will automatically forfeit his/her seat.

The courses of studies in Nalbari College are full-time courses. No student shall take any other full-time course simultaneously.

Harassing juniors, ill treatment to other fellow students or ragging in any form is objectionable and liable to be treated as criminal offence by the law enforcing agencies as per the directives of Honourable Supreme Court of India.

All the students are expected to attend all college functions in college uniform unless otherwise specified. Any dress code violation noticed within the campus will attract a fine of Rs.300 and could initiate further disciplinary actions.

All the students shall wear their identity cards, well displayed. Any teaching or non teaching staff shall have the right to verify it.

Careful handling of the furniture, equipments, fixtures and appliances of the College is a must. In the event of any misuse/careless handling/damage of property, the responsible students will have to bear the cost of replacement/repair with fine.

Political activity in any form by students and Students' Organizations are strictly prohibited in the College campus. Unauthorized meetings, propaganda work, celebrations, decorations, processions or fund collections are forbidden within the College, in hostels, and even outside the College campus.

Misbehavior or disrespect towards girl students, use of threat or violence against members of the teaching and non- teaching staff or fellow students will be considered as very serious cases of misconduct.

Students must not loiter in the corridors and in front of the class rooms and keep quiet as much as possible during College hours.

Use of mobile phone and other electronic gadgets inside classroom will fall under the breach of discipline. Mobile phones are not allowed inside examination hall.

Chewing of tobacco and spitting will amount to a fine of **Rs. 1000/** without fail and may cause expulsion from the College.

